

# Assembly Instruction for AKO Pinch Valve

## Series VM+VMF DN 10 to 50 mm

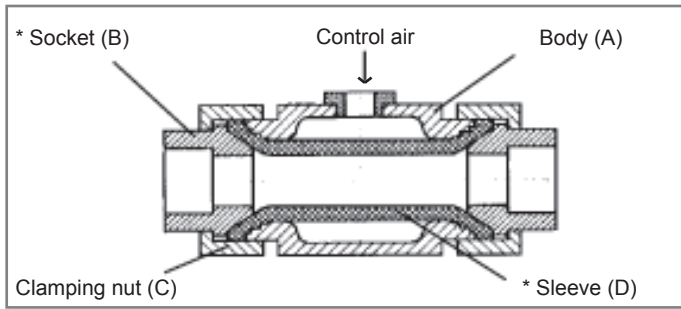

### Removing the old sleeve

Put pinch valve in a vice.  
Loose both nuts (C).  
Pull out old sleeve (D) by using a pipe wrench.  
Clean all valve parts and inspect for wear (i.e. sharp edges).

### Installation of the new sleeve

**Picture 1:** Push sleeve (D) into body (A) until it is centred.  
In case it is too hard, please use AKO mounting paste (MP200) in-between sleeve and body.

**Caution:** Spread threads by using grease paste (GLP805).

**Picture 2:** Spread inside and outside surfaces of sleeve (D) and cones of sockets (B). Use AKO mounting paste.

**Caution:** Do not use any grease or oily paste.

**Picture 3+4:** Hold the body and sleeve assembly. Push the socket (B) so that the cone fits into the sleeve (D). Pushing it in with your thumb and then put ring (C) on to the body.

**Picture 5:** Turn the valve by 180°. Assemble second socket (B) with ring (C).

**Picture 6+7:** Put the valve unit into a vice in a horizontal position and tighten until the sockets are nearly touching the body surface. Tighten nuts hand tight.

**Caution:** Don't use any separate tool.

**Functional test:** When closing the Pinch Valve for the first time, a control pressure of 4BAR must be applied to enable the sleeve to close fully, showing a lip-shaped form in the sleeve.

\*Replacement-/Maintenance parts:

Sleeve (D) and sockets (B).

Assembly tool: AKO mounting paste MP200



Picture 1



Picture 2



Picture 3



Picture 4



Picture 5



Picture 6



Picture 7

Technical details subject to change without notice.

**AKO UK Ltd**

12 Rutherford Way, Drayton Fields Industrial Estate, Daventry, Northamptonshire, NN11 8XW

Tel: 01327 312 747 • Fax: 01327 312 565 • E-mail: sales@ako-valves.com • Web: www.pinch-valves.com