

Assembly Instruction for AKO Pinch Valves

Series OV type P-PA (with one pneumatic cylinder)

Type P

Step 1: Remove the sleeve fixing screw (18) from the lower body half (03).

Step 2: Remove the body half screws (16) of the body halves (02/03). Supply air to the cylinder (15) to close the valve.

Step 3: Unscrew the sleeve fixing screws (17) and remove the sleeve (04).

Step 4: Replace the sleeve (04) and mount the sleeve fixing screws (17).

Step 5: Supply air to the cylinder (15/15F) to open the valve and fix the body half screws (16). Mount the sleeve fixing screw (18) on the lower body half (03).

Operate the valve several times and check for easy running closing and opening.

Type PA

Step 1: Supply air to the cylinder (15F). Remove the sleeve fixing screw (18) at the lower body half (03).

Step 2: Remove the body half screws (16) of the body valve (02/03). To close the valve deflate the cylinder. (15F).

Step 3-5: see type P

Code	Description	Quantity
02	Upper body half	1
03	Lower body half	1
04	Sleeve	1
05	Pinch bar	1
15	Cylinder double acting	1
15F	Cylinder single acting (spring closed)	1
16	Body half screws	4
17	Sleeve fixing screws	2
18	Lower Sleeve fixing screw	1

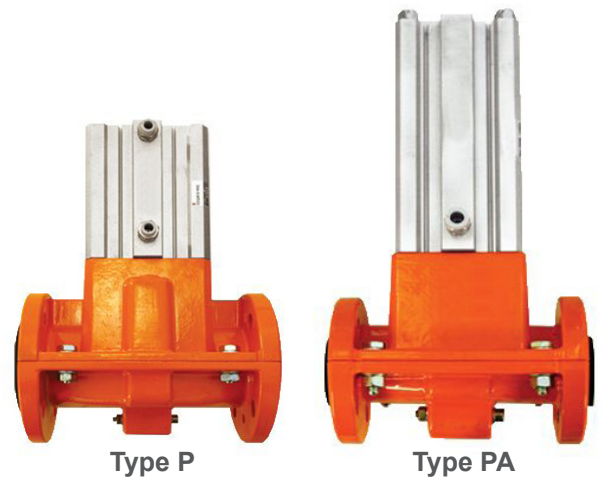

P: DN 15 - 50mm
with one double acting cylinder

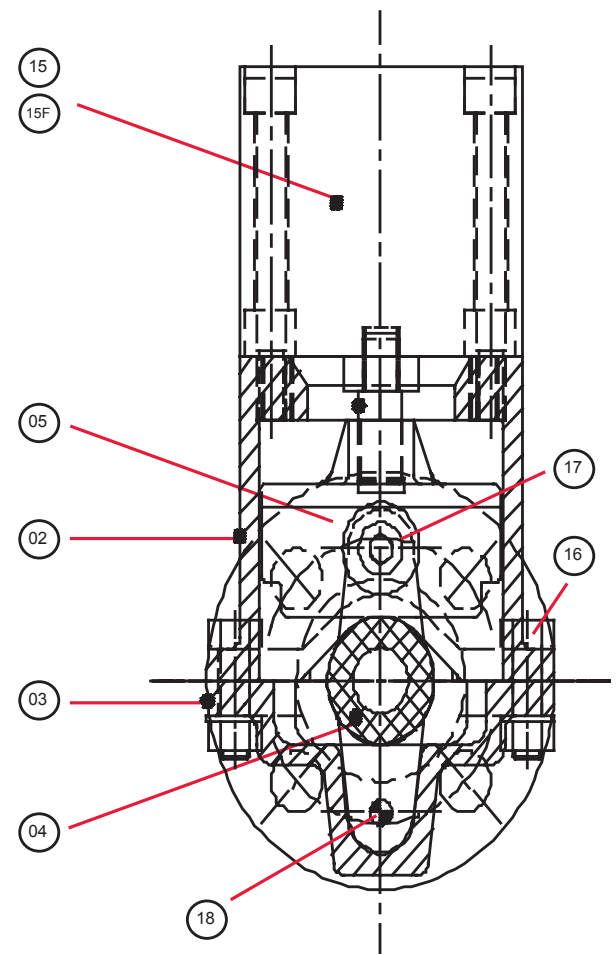

PA: DN 15 - 50mm
with one single acting cylinder
The valve is spring closed.

Technical details subject to change without notice.