

Air operated Pinch Valves type VT

Aluminium design with semi-silo trailer connection acc. to DIN28459



- Free passage
- Optimum tightness
- Low resistance
- No plugging
- Low weight
- Easy maintenance

 The ideal valve solution for abrasive, corrosive and fibrous products like granules, powders, solids of all kinds and so on.

Industrial areas:

- Silo-trailers
- Semi-trailers
- Haul trucks



Air operated Pinch Valves type VT

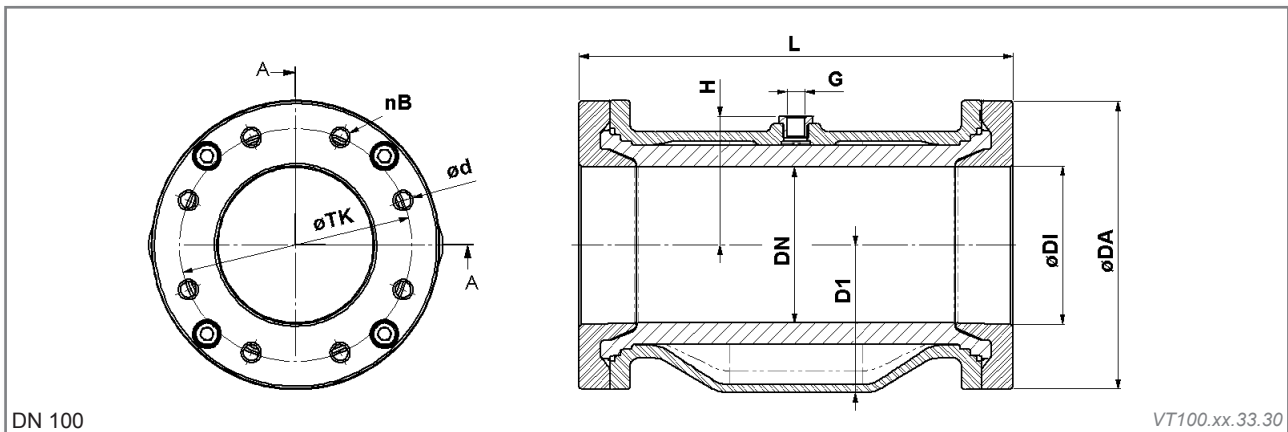
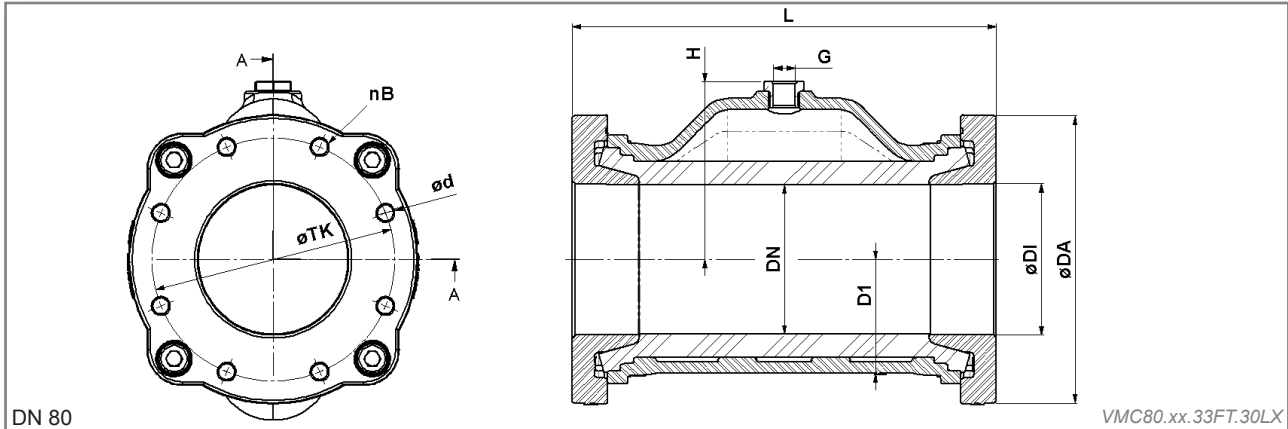

DN /DI (mm)	DA (mm)	D1 (mm)	d (mm)	nB	screws	TK (mm)	L (mm)	H (mm)	G (inch)	PS max (bar)	weight (kg)	Volume (l)* (approx)
80	154,5	86	M10x1,5	8	4	130	227	95	G 1/4"	6	4,1	0,88
100	185	95	M12x1,75	8	4	150	280	83	G 1/4"	6	6,1	1,5

Volume = Control volume with closed sleeve

Materials:

Valve body: Aluminium unpainted, (DN80 painted)

Flange: Aluminium unpainted

Sleeves:

Natural rubber (NR) anti-abrasive, NR food quality, NR high temp., NBR, NBR food quality, EPDM, EPDM food quality, CR, IIR, CSM

Accessories:

Solenoid valves, pressure switch, safety arrangement, vacuum unit etc.

Pinch Valve Accessories to be found on our data sheet

"Z01"-Pinch Valve Accessories.

Technical details subject to change without notice.

AKO UK Ltd.

12 Rutherford Way, Drayton Fields Industrial Estate, Daventry, NN11 8XW, Great Britain

Tel: 0 13 27 31 27 47 • Fax: 0 13 27 31 25 65 • E-mail: sales@ako-valves.com • Web: www.pinch-valves.com